



7P.01/03/05/07 SPD Class I



Utility Model - IB7P01VXX - 11/19  
Finder S.p.A. con unico socio  
10040 ALMESE (TO) - ITALY

Type	I <sub>PE</sub> (μA)	U <sub>c</sub> V AC (L-N)	U <sub>0</sub> V AC	Number of port	Dimensions L x W x H (mm)	Approvals	TOV L-N		TOV L-PE	TOV N-PE	System
							5s	120 min	200 ms	200 ms	
7P.01.8.260.1025	< 4	260	230/400 ± 10%	One Port SPD	94 x 36 x 66	VDE, EZU	335 V	440 V	-	-	-
7P.03.8.260.1025	< 4	260			94 x 108 x 66	VDE, EZU	335 V	440 V	-	-	TN-C
7P.05.8.260.1025	< 4	260			94 x 144 x 66	VDE, EZU	335 V	440 V	-	-	TN-S
7P.07.8.260.1025	< 4	260			94 x 72 x 66	VDE, EZU	335 V	440 V	-	-	TN-S

Minimum distance from earthed conductive surface: d = 0

I <sub>imp</sub> (10/350)	25 kA
I <sub>n</sub> (8/20)	30 kA
I <sub>max</sub> (8/20)	60 kA
I <sub>SCCR</sub>	50 kA <sub>rms</sub>
I <sub>L</sub> V-connection	max 125 A
V-connection	max 125 A gL/gG
	max 250 A gL/gG
%	5%...95%
°C	-40...+80°C

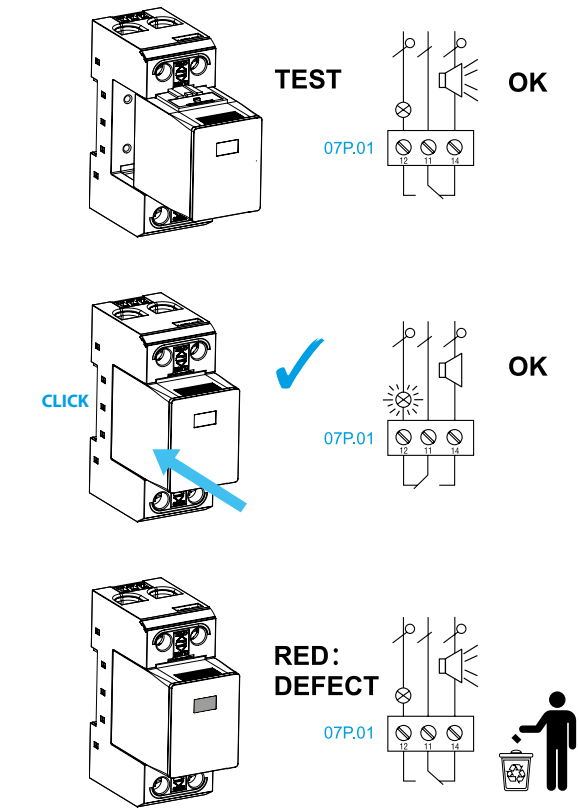
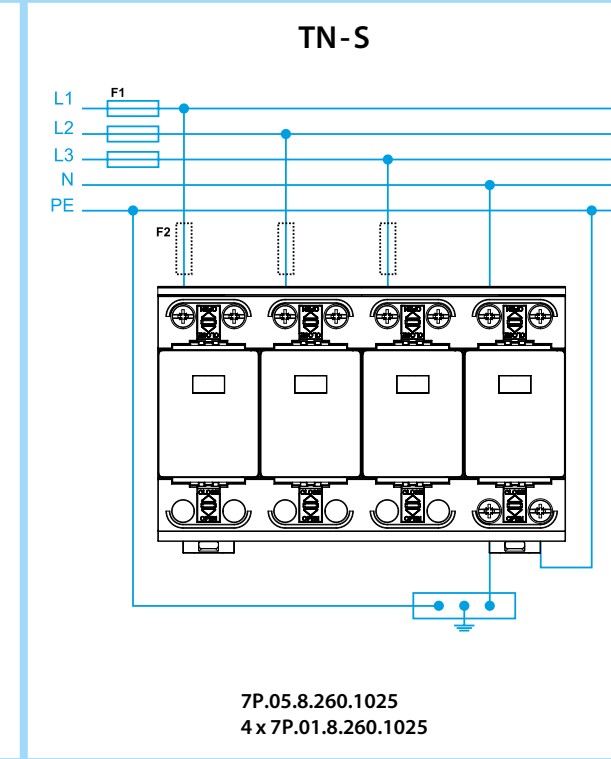
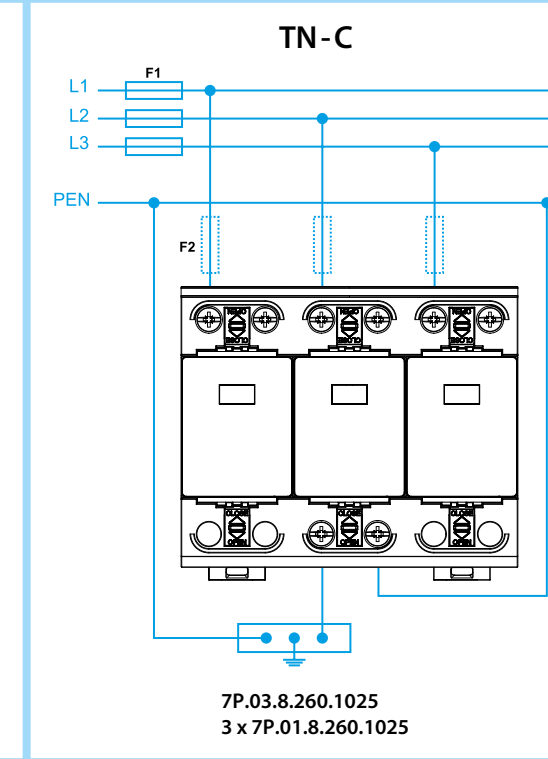
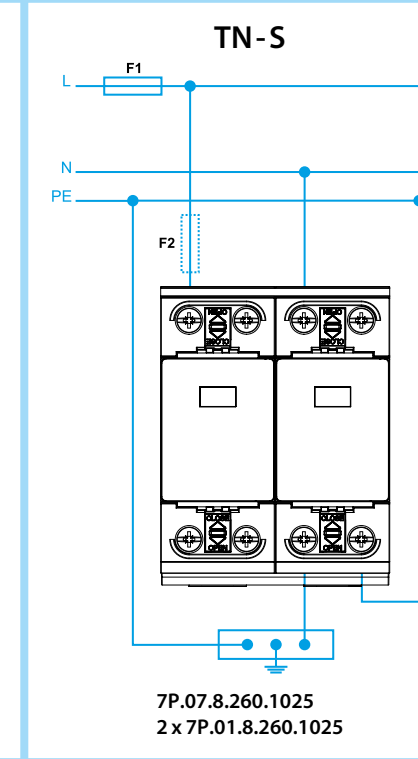
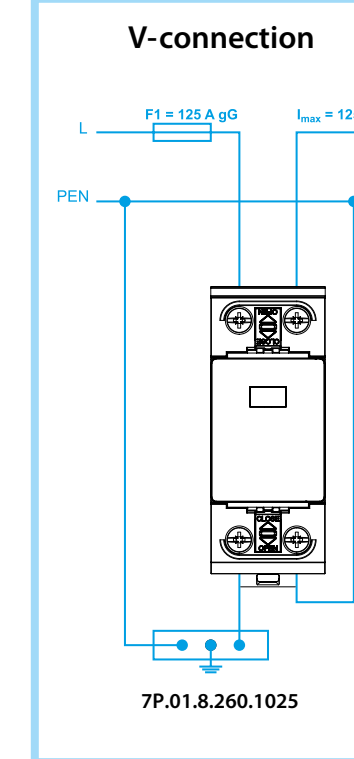
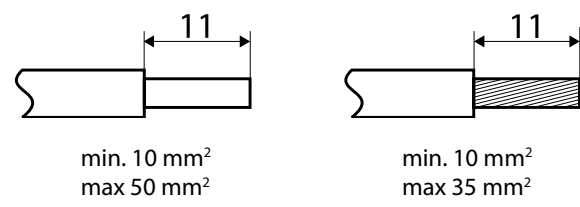
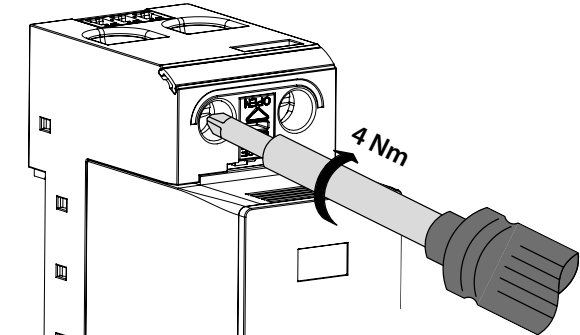
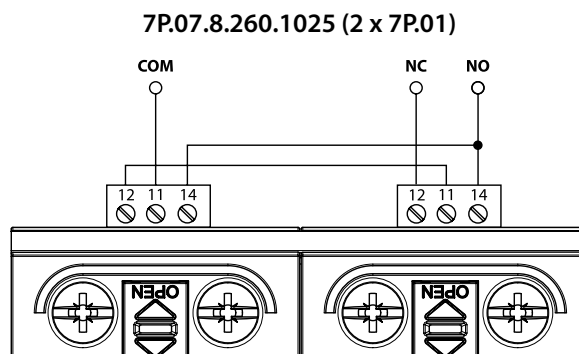

07P.01	1 CO (SPDT)
	0.5 A (AC) 250 V AC
	0.1 A (DC) 250 V DC
Max	1.5 mm <sup>2</sup> / 30 AWG

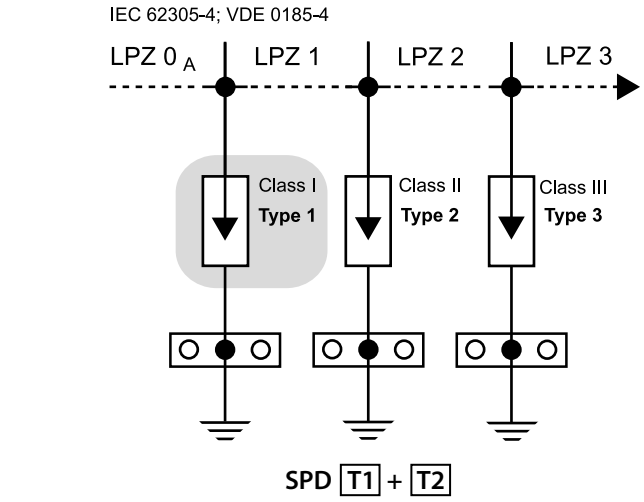
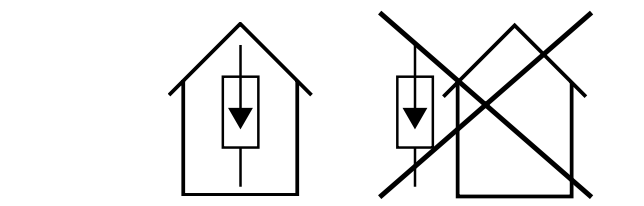
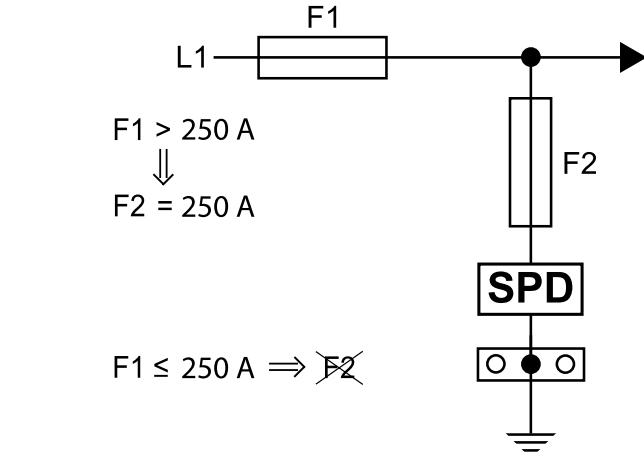
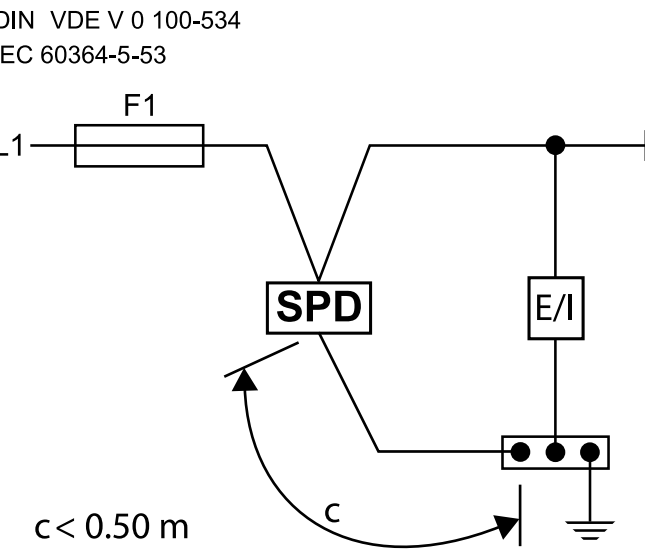
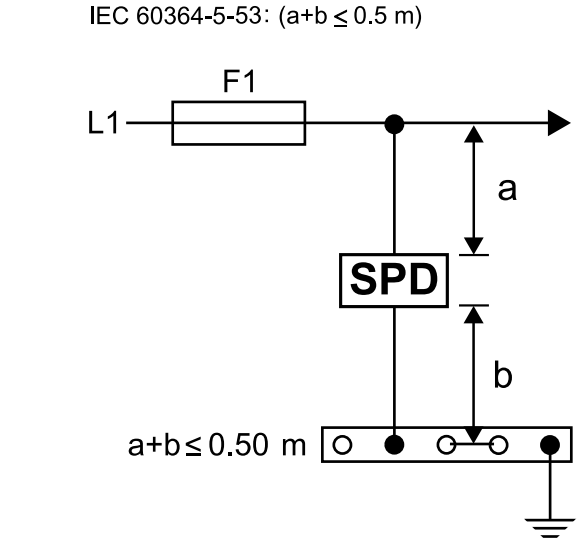

# ESPAÑOL

Los SPD Finder de la serie 7P deben ser instalados sólo por personal cualificado, respetando las normativas vigentes de instalaciones eléctricas en edificios (IEC 60364-5-53, VDE 0100-534...).

Antes de la instalación asegúrese que el componente no esté dañado o haya sido expuesto a bajas temperaturas en modo de evitar condensación interna. Cualquier manipulación indebida del componente cesará el derecho de garantía.

Es importante respetar los valores del fusible de seguridad aconsejados y asegurarse que la tensión nominal de la instalación sea inferior al valor U<sub>c</sub>.

En caso que se tengan que efectuar mediciones de aislamiento en la instalación, es preciso extraer todos los cartuchos de las bases para obtener medidas exactas. Al término de la medición insertar de nuevo los cartuchos en las bases del SPD.

